



# GRUPO ETRA

## eMobility

Transport Area

Antonio Marqués  
Director of New Technologies  
ETRA I+D

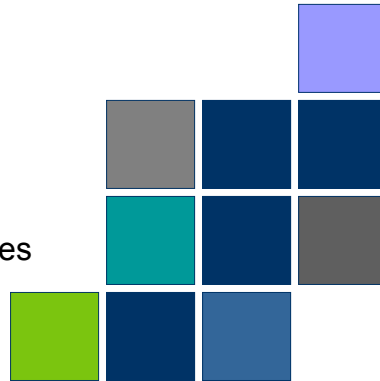

[amarques.etra-id@grupoetra.com](mailto:amarques.etra-id@grupoetra.com)



GRUPO ETRA

## *Index*

- **GRUPO ETRA**
- Current situation of Transport
- Relevance of Wireless Communications in Transport Technologies and applications
  - V2I and V2V
- CALM Architecture
- COMeSafety Initiative
- Frame – Reference Architectures
- Relevant Projects
- Examples of leading-edge applications
  - Infotainment
  - Incident detection and broadcast of information – V2V and V2I
  - Personalised information to vehicles to improve traffic management





## ***ETRA is a high tech industrial group***

- Part of ACS, the 4th largest Construction and Services Corporation in the World.
- ETRA has 2.000 employees and a turnover of +230M€.
- Market leader in ITS, technology and mobility.
- ETRA's activities include:
  - Intelligent Transportation Systems
  - Fleet management, integrated public transport solutions
  - Integrated Traffic Management –urban, interurban, tunnels, etc.
  - Electronic toll collection, e-ticketing
  - Personalised, location based services
  - Parking management
- From basic research to turnkey systems delivery



## ***Index***

- GRUPO ETRA
- **Current situation of Transport**
- Relevance of Wireless Communications in Transport Technologies and applications
  - V2I and V2V
- CALM Architecture
- COMeSafety Initiative
- Frame – Reference Architectures
- Relevant Projects
- Examples of leading-edge applications
  - Infotainment
  - Incident detection and broadcast of information – V2V and V2I
  - Personalised information to vehicles to improve traffic management





## **Challenges in the Transport Area**

One of the key objectives of transport technologies is to provide new solutions to improve security and efficiency in transport by means of generating useful knowledge related to the new technologies, infrastructures and services to improve safety and to provide more comfortable driving.

Transport has new challenges related to improve mobility:

- Focused on people
- More reliable, safe and comfortable trips
- Intelligent and cooperative transport networks
- **Interconnection between vehicles and infrastructures**

The achievement of these challenges imply emerging developments in key areas of research:

- HMI
- Sensors
- Computing Capacity
- Embedded Systems
- **Wireless Communications**



## **Index**

- GRUPO ETRA
- Current situation of Transport
- **Relevance of Wireless Communications in Transport Technologies and applications**
  - **V2I and V2V**
- CALM Architecture
- COMeSafety Initiative
- Frame – Reference Architectures
- Relevant Projects
- Examples of leading-edge applications
  - Infotainment
  - Incident detection and broadcast of information – V2V and V2I
  - Personalised information to vehicles to improve traffic management





### ***Wireless Communications in Transport Technologies and Applications***

- Wireless Communications in Transport imply three key areas:
  1. Communications vehicle to vehicle
  2. Communications vehicle to infrastructure
  3. Communications with the telecommunication public networks
  
- Currently, the main problem we face when dealing with wireless communications in transport is that there does not exist a satisfactory solution to some relevant aspects fo V2X communications:
  - a. Simultaneous wireless access of high number of vehicles
  - b. Allocation and re-distribution of frequencies
  - c. Routing protocols in network topologies continuously changing and with a variable density of elements
  - d. Discovering of available gateways, elements and services in the infrastructure
  - e. Data flow prioritization mechanisms



**Continuous research is required to solve these issues**



### ***Index***

- GRUPO ETRA
- Current situation of Transport
- Relevance of Wireless Communications in Transport Technologies and applications
  - V2I and V2V
- **CALM Architecture**
- COMeSafety Initiative
- Frame – Reference Architectures
- Relevant Projects
- Examples of leading-edge applications
  - Infotainment
  - Incident detection and broadcast of information – V2V and V2I
  - Personalised information to vehicles to improve traffic management



## CALM architecture

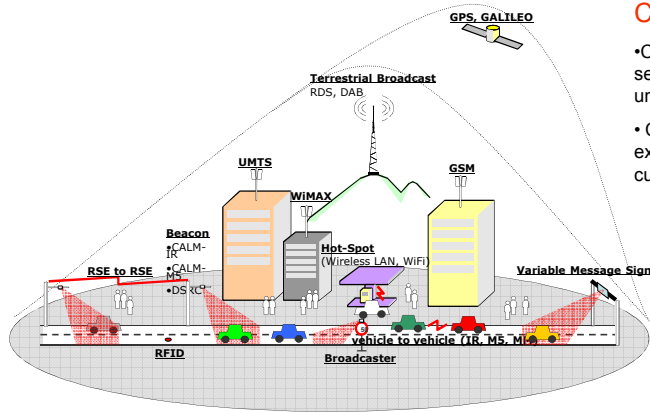

### CALM Architecture

- CALM produce an integration of a set of comm tech, managing all as a unique CALM layer.
- CALM system could provide an excellent model in order to define customised operational framework.

## Index

- GRUPO ETRA
- Current situation of Transport
- Relevance of Wireless Communications in Transport Technologies and applications
  - V2I and V2V
- CALM Architecture
- **COMeSafety Initiative**
- Frame – Reference Architectures
- Relevant Projects
- Examples of leading-edge applications
  - Infotainment
  - Incident detection and broadcast of information – V2V and V2I
  - Personalised information to vehicles to improve traffic management

## COMeSAFETY Objectives

- Co-ordination and consolidation of research results and their implementation**  
 Co-ordination and consolidation of the results emerging of the European and national projects as well as the outcomes of initiatives like the CAR 2 CAR Communication Consortium (C2C-CC) to prepare the standardisation process with respect to all technologies for vehicle-to-vehicle and vehicle-to-infrastructure communications
- eSafety Forum support**  
 Support of the eSafety Forum, especially the Working Group Communications, by promoting information flows, summing up major research results, giving feedback on implementation progress, forwarding and explaining recommendations from the Forum and providing input concerning deployment strategies
- Worldwide harmonization**  
 Harmonization with activities and initiatives elsewhere in the world, particularly with the VSC and VII consortia in the US and programs like AHSRA and ASV3 in Japan
- Frequency allocation**  
 Support of spectrum allocation for ITS applications, mainly for safety related car to car/infrastructure communication through cooperation with the European regulation bodies and the technical WGs of ETSI
- Dissemination**  
 Dissemination of system properties towards all stakeholders, e.g. general public, industrial players, road operators, European and national authorities etc. to prepare system introduction



## Aim of COMeSafety: New Consolidation Process

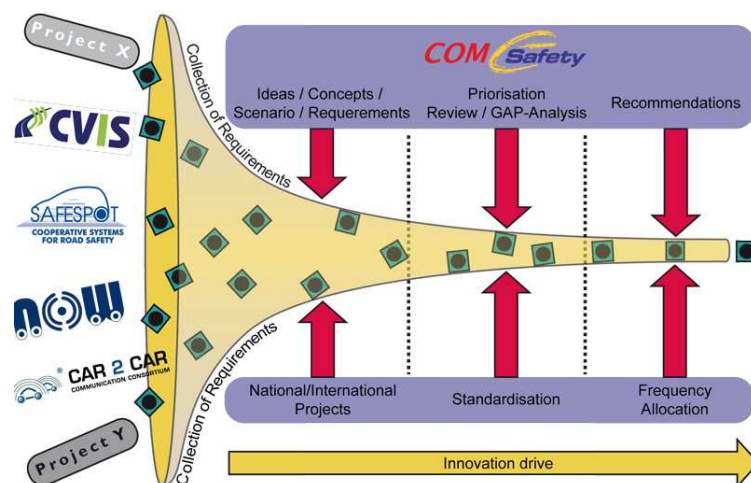



## ***Index***

- GRUPO ETRA
- Current situation of Transport
- Relevance of Wireless Communications in Transport Technologies and applications
  - V2I and V2V
- CALM Architecture
- COMeSafety Initiative
- **Frame – Reference Architecture**
- Relevant Projects
- Examples of leading-edge applications
  - Infotainment
  - Incident detection and broadcast of information – V2V and V2I
  - Personalised information to vehicles to improve traffic management



## ***Frame***

- Defines 8 main functional areas
  - 1. Provide Electronic Payment Facilities
  - 2. Provide Safety and Emergency Facilities
  - 3. Manage Traffic
  - 4. Manage Public Transport. Provide Advanced Driver Assistance
  - 6. Provide Traveller Journey Assistance
  - 7. Provide Support for Law Enforcement
  - 8. Manage Freight and Fleet Operations



### Operational Management: Frame General View

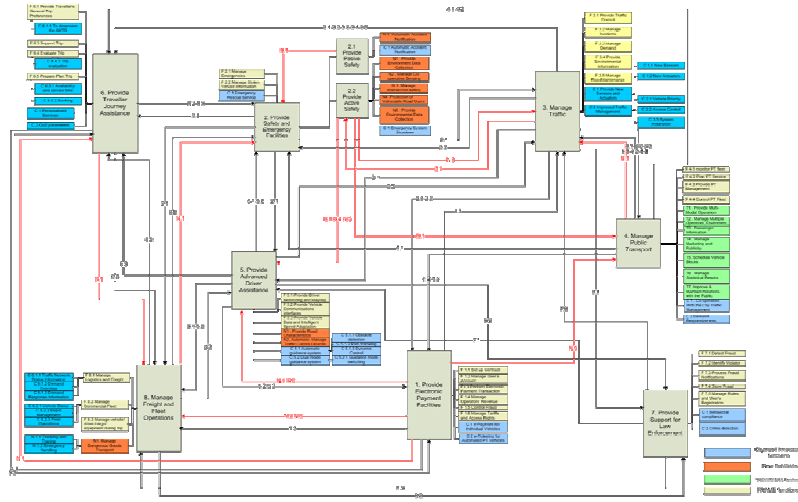

### Example

- **Area2. Provide Safety and Emergency Facilities**

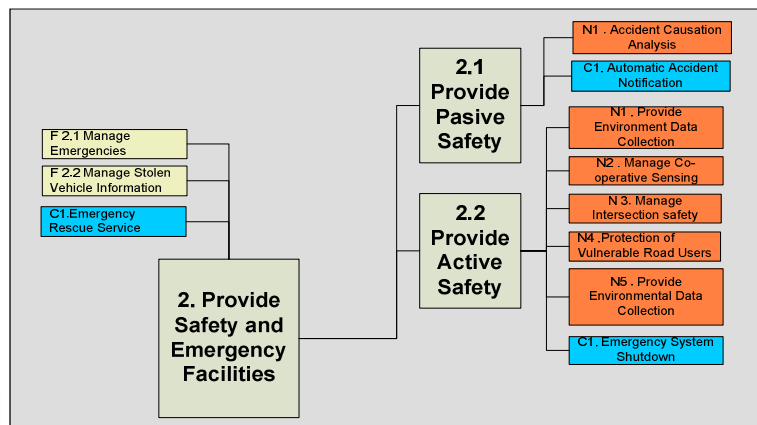

## *Index*

- GRUPO ETRA
- Current situation of Transport
- Relevance of Wireless Communications in Transport Technologies and applications
  - V2I and V2V
- CALM Architecture
- COMeSafety Initiative
- Frame – Reference Architecture
- **Relevant Projects**
- Examples of leading-edge applications
  - Infotainment
  - Incident detection and broadcast of information – V2V and V2I
  - Personalised information to vehicles to improve traffic management



## • Relevant Projects



**•Project overview**

•Design, develop and test the technologies needed to allow cars to communicate with each other and with the nearby roadside infrastructure.

**• CVIS project provide a set of services to the drivers**

•Speed limits and other road sign information, as well as warnings of approaching emergency vehicles and similar urgent messages will be sent wirelessly to the vehicle.

•Drivers can influence the traffic control system directly and get individual guidance with the quickest route to their destination



**Useful communication architecture on board**

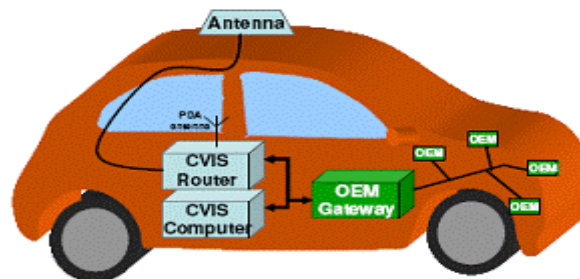

*Vehicle-Infrastructure approach*

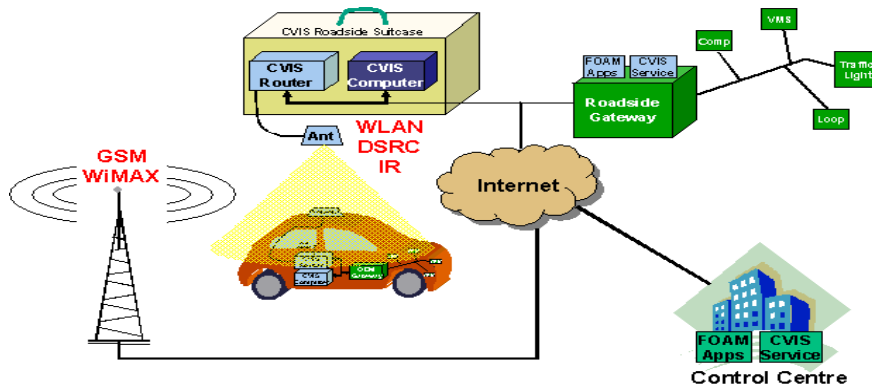

**Project Overview**

- COOPERS is a IP focused to the application of a real time data communication between infrastructure and vehicle to exchange safety related information (e.g. speed, road conditions, lane change by passing, local traffic conditions, etc.)

**Information services**

- Speed guidance
- Warning messages
- End of traffic jam propagation
- Selective line ban for trucks
- Speed alerts



*Useful communication architecture on board*

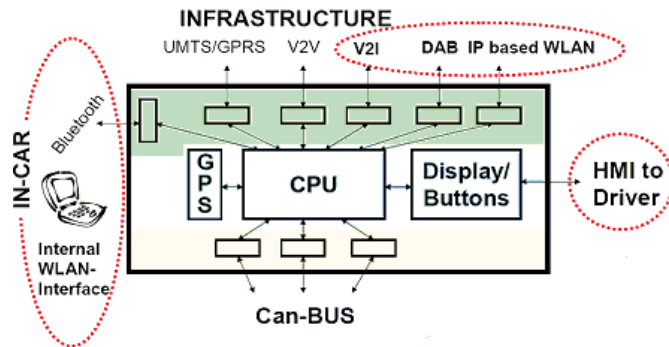

*Vehicle-Infrastructure approach*

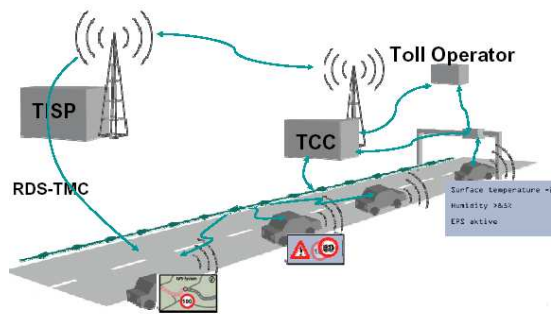

**Road side data acquisition**

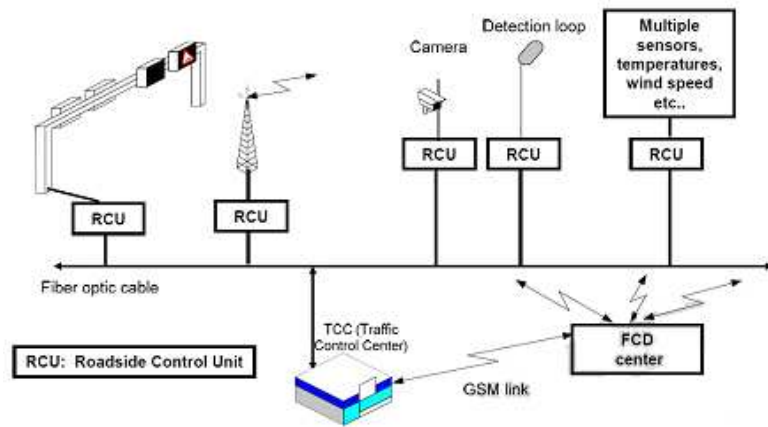

**Project overview**

IP PreVENT creates a 'virtual safety belt' around the vehicle by:

- Developing a set of complementary safety functions
- Exploiting sensor data fusion, maps and communication technologies
- Using an integrated approach to increase system capabilities and achieve optimum cost-benefit ratio

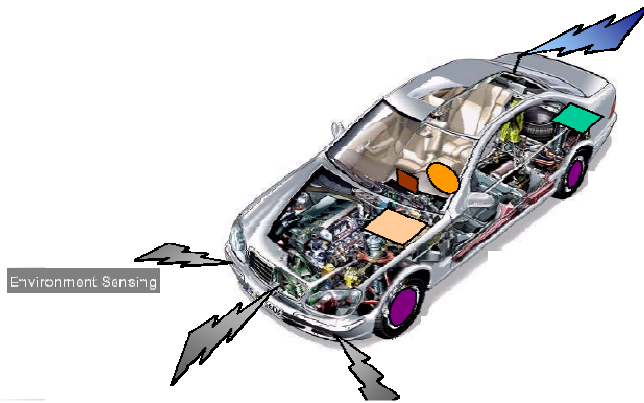

### ***Project Overview***

•Electronic Architecture and System Engineering for Integrated Safety Systems

•Develop a standardised in-vehicle electronic architecture and a standardised system engineering approach for integrated safety systems.

•EASIS use a combination of active and passive safety systems over vehicle domains or networks to improve safety.



*In-Vehicle Architecture*

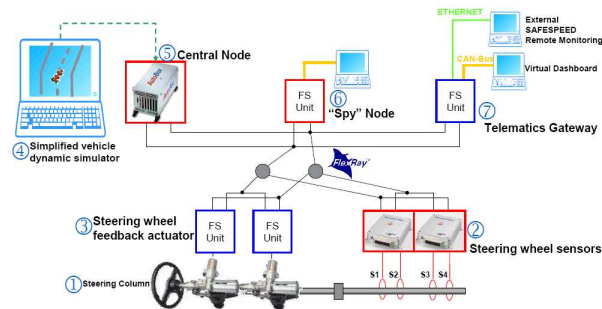

**Project Overview**

GST is a set of sub projects (EFCD)

1. Enhanced Floating Car Data  
Standardized interfaces to provide relevant information and detection (external services providing traffic or weather information, internal services for map data etc.
2. Certification
3. Security
4. Rescue
5. Open systems
6. Service payment
7. Safety Channel

Enhanced Floating Car Data

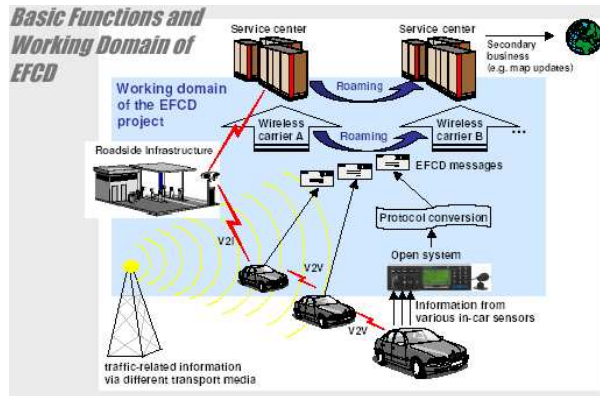

Other projects that covers V2I and V2V communications

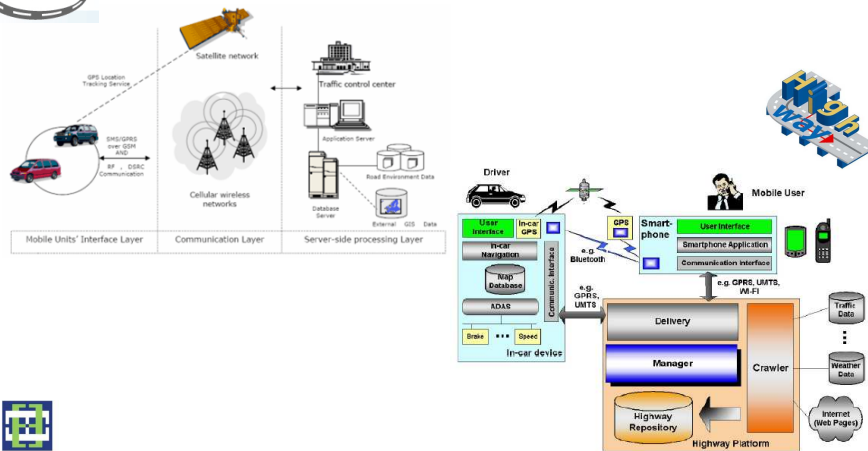



## ***Index***

- GRUPO ETRA
- Current situation of Transport
- Relevance of Wireless Communications in Transport Technologies and applications
  - V2I and V2V
- CALM Architecture
- COMeSafety Initiative
- Frame – Reference Architecture
- Relevant Projects
- **Examples of leading-edge applications**
  - **Infotainment**
  - **Incident detection and broadcast of information – V2V and V2I**
  - **Personalised information to vehicles to improve traffic management**



## ***Examples on Leading-Edge Applications***

### **- Personalised information to vehicles to improve traffic management**

The traffic status can be improved if vehicles are aware of the congested/problematic areas

Traffic management can take an additional dimension if the infrastructure is able to provide personalised instructions to vehicles to redirect them avoiding conflictive areas

Instructions would be between the road side units and the vehicle navigator and completely transparent to the driver

### **- Infotainment**

Development of an information and entertainment system that allows navigation, music download and sharing and films purchase and download

Additional contents availability can be searched in the vehicles driving around and if found, they can be shared.

### **- Incident detection and broadcast of information**

Safety can be improved if a vehicle that detects an obstacle or an incident is able to broadcast this information to the rest of vehicles quickly enough so that the coming vehicles can react to the situation

Furthermore, if the same information is sent to the infrastructure, the appropriate traffic management measures can be taken –information panels updated, emergency services notified, etc.



 GRUPOETRA \_\_\_\_\_



GRUPOETRA

Avda. Tres Forques 147 . 46014 Valencia  
Tel. +34 96 313 40 82 . Fax +34 96 350 32 34  
[www.grupoetra.com](http://www.grupoetra.com)

